

Extruded Aluminum Louver • 6" Deep • 35° Drainable Blades • Airfoil Adjustable Blades • Concealed Actuator

Standard Construction and Materials

FRAME: .081" thk. (nominal) extruded aluminum, 6063-T52/T6 alloy. Channel type.

BLADES: Stationary blades are made from .081" thk. (nominal) extruded aluminum 6063-T52/T6 alloy. Adjustable Airfoil blades are made from .125" thk. (nominal) extruded aluminum 6063-T52/T6 alloy. Blades are approximately 4½" on centers.

LOUVER FACE: Full width sill with head and blades contained within jambs.

SHAFT: .50" dia. aluminum "Pin-Lock" rod.

LINKAGE: Extruded aluminum, concealed in the channel out of the airstream. The pivots, which rotate in Celcon bearings, are .50" dia. Cadmium plated and Chromate treated machined steel. The pivot is locked to the 5/16" dia. aluminum linkage rod by a ¼ - 20 set screw with epoxy locking patch.

SEALS: Extruded silicone rubber seals at blade edge. Foam on bottom blade. Stainless steel at jambs.

SCREEN: (When indicated, in a removable frame)

½" flattened aluminum, .051" thk.,

-or- Insect screen 19/64 aluminum mesh, .011" dia.,

-or- ½" sq. mesh intermediate double crimped aluminum wire, .063" dia.

FINISH: Mill.

ACTUATOR: 120 VAC spring return normally closed. 133 in.-lbs. torque.

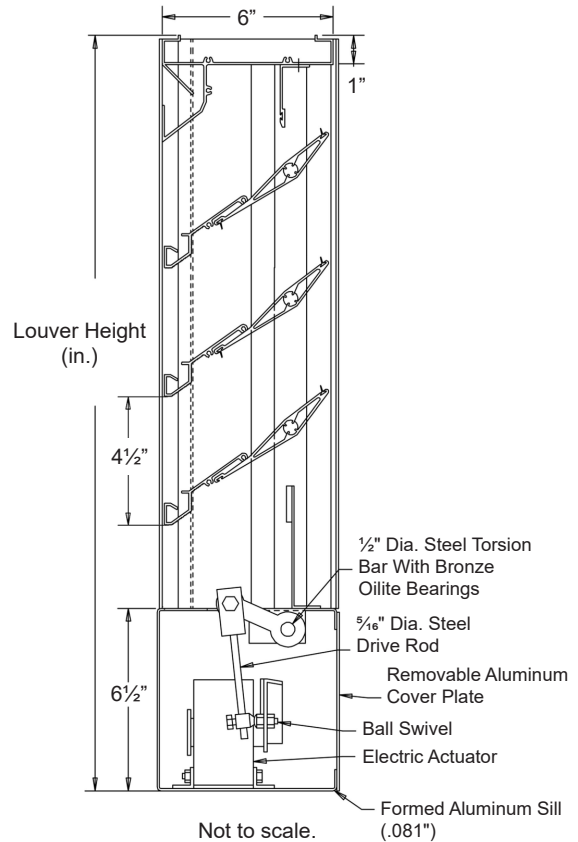

Not to scale.

Options

Finishes - Enamels, Epoxies, etc.
Other screens also available.

Notes

1. Nominal deductions will be made to the opening size given.
2. Approximate shipping weight is 5.7 lbs./sq.ft.

Louver Sizes

Min Panel	Max Single Panel
12"W x 19"H	48"W x 96"H

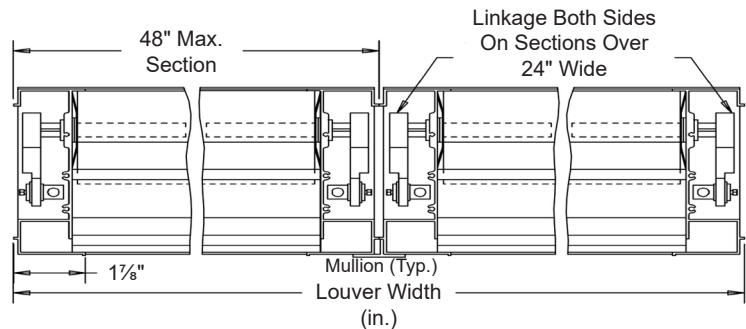

Item #	Qty	Width	Height	Width	Height	Mullion	Type	Location	Screens	Union Made
		Opening Size		Louver Size						
Arch. / Eng.:						EDR:		ECN:		Job:
Contractor:										
Project:						Date:		DWN:		DWG:

In the interest of product development, Cesco Products reserves the right to make changes without notice.



450 Riverside Dr • Wyalusing PA, 18853
Phone: 570-746-1888 • Fax: 570-746-9286
www.cescoproducts.com